

Questions

Q1.

This question is about hydrochloric acid.

(a) Dilute hydrochloric acid, HCl(aq), reacts with many metals.

A student observes the reaction of dilute hydrochloric acid with four metals, P, Q, R and S.

She uses the same amount of metal in each case.

The table shows her observations.

Metal	Observations
P	very few bubbles produced very slowly
Q	many bubbles produced very quickly
R	many bubbles produced quickly
S	few bubbles produced slowly

(i) Use the information in the table to place the four metals in order of reactivity.
Place the most reactive first.

(2)

most reactive

least reactive

(ii) Give the names of the two products formed when magnesium reacts with dilute hydrochloric acid.

(2)

Product 1

Product 2

(Total for question = 4 marks)

Q2.

Many chemical reactions occur in the atmosphere.

(a) The pie chart shows the relative amounts of some gases in air.

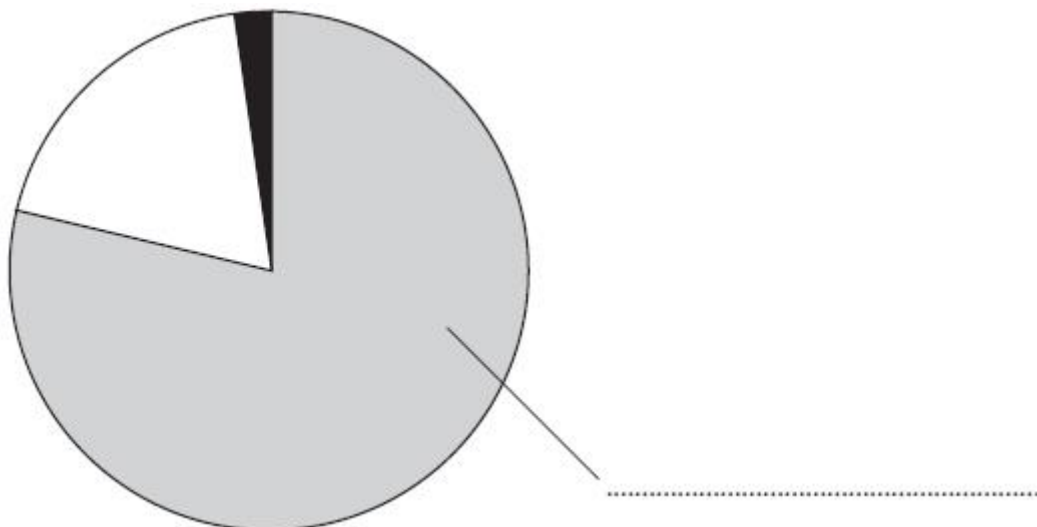

(i) Label the pie chart with the name of the gas that makes up most of the air.

(1)

(ii) What is the approximate percentage of oxygen in air?

Place a cross (X) in one box.

(1)

1

20

25

78

(b) Rain water is naturally slightly acidic because carbon dioxide dissolves in it. The word equation for the reaction that occurs is:



Acid rain is more acidic because pollutant gases in the atmosphere also dissolve in water.

(i) Identify the acid formed when sulfur dioxide reacts with water.

(1)

.....
(ii) Identify another pollutant gas that forms acid rain.

(1)

.....
(iii) State **two** problems caused by acid rain.

(2)

1
.....
.....

2
.....
.....

(Total for Question = 6 marks)

Q3.

A student wants to find out if the green colouring in grass is a mixture of dyes.

He uses a solvent to dissolve the green colouring from some grass.

He then separates the solution of the green colouring from the remaining grass.

(a) Which of these methods is used to separate the solution of the green colouring from the remaining grass?

(1)

- A boiling
- B condensation
- C evaporation
- D filtration

(b) The student uses a dropping pipette to place a drop of the green solution onto a piece of chromatography paper and produces a chromatogram.

The diagram shows his results.

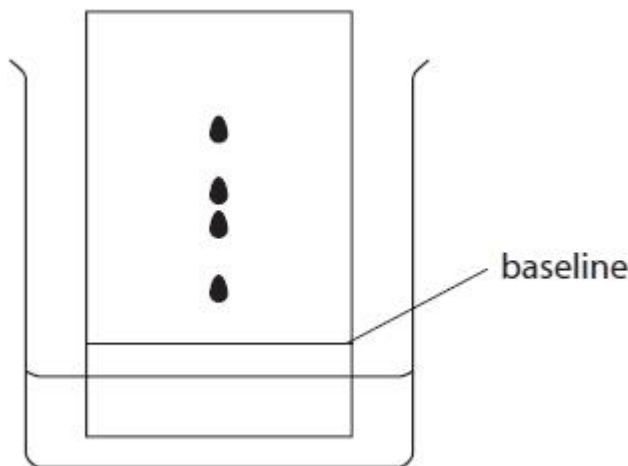

(i) Add three more labels to the diagram to show

- the solvent
- the chromatography paper
- the original position of the spot of the green solution

(3)

(ii) Explain how many different dyes are present in the green colouring.

(1)

.....

.....

.....

(Total for question = 5 marks)

Q4.

The diagram shows the apparatus a student uses to separate a mixture of salt and sand.

She adds the mixture to water in a beaker and then carries out the three stages shown.

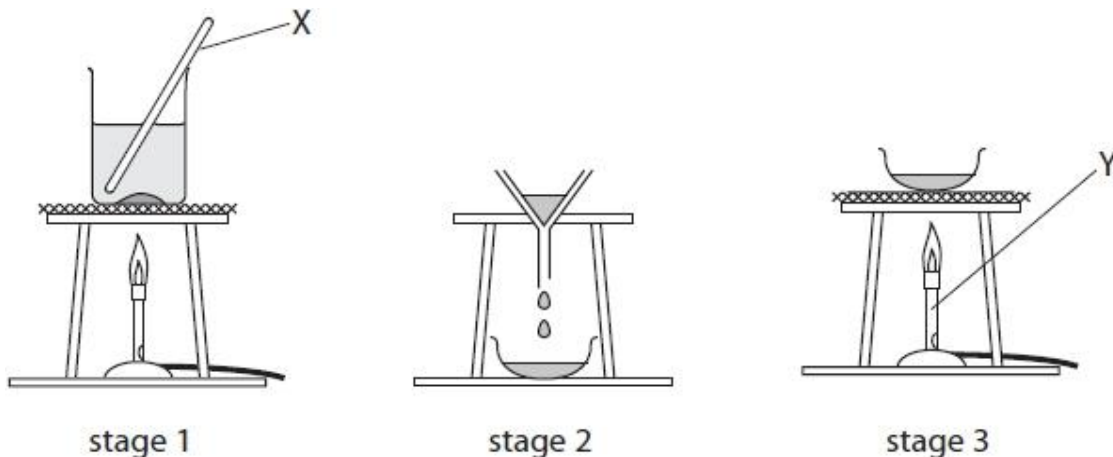

(a) Give the names of the pieces of apparatus labelled X and Y.

(2)

X

Y

(b) (i) A liquid that dissolves substances is a

(1)

- A solute
- B solution
- C solvent
- D suspension

(ii) The clear liquid that forms in stage 1 is a

(1)

- A solute
- B solution
- C solvent
- D suspension

(c) (i) At which stage, 1, 2 or 3, is the sand collected?

(1)

.....

(ii) At which stage, 1, 2 or 3, is the salt collected?

(1)

.....

(d) What happens to the water in stage 3?

(1)

.....

.....

(Total for question = 7 marks)

Q5.

A student produces this chromatogram for four dyes, **A**, **B**, **C** and **D**.

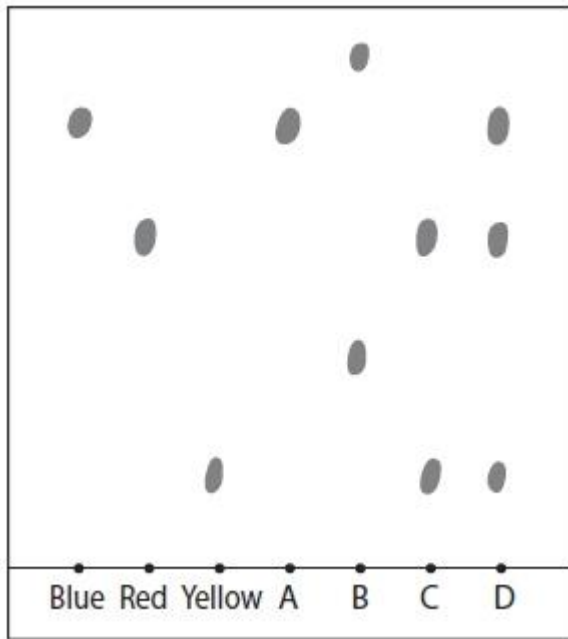

(a) Put a cross (☒) in a box to indicate your answer.
 (i) Which one of the dyes contains three colours?

(1)

- A**
- B**
- C**
- D**

(ii) Which one of the dyes contains one colour only?

(1)

- A**
- B**
- C**
- D**

(b) Each dye is made from one or more of the colours blue, red and yellow.
 The student thinks that the result for one dye is incorrect.
 Suggest which result is incorrect. Explain your answer.

(2)

The incorrect result is

.....

because

.....

(Total for Question = 4 marks)

Q6.

The table shows the names of some common pieces of laboratory apparatus used to make measurements.

(a) Complete the table to show the name of the quantity that can be measured by each piece of apparatus, and a common unit used for that quantity. One example of each has been done for you.

(6)

Apparatus	Quantity	Unit
balance	mass	
stop clock		s
gas syringe		
ruler		

(b) Which piece of apparatus is needed to make measurements in a paper chromatography experiment?

(1)

- A balance
- B gas syringe
- C ruler
- D stop clock

(Total for question = 7 marks)

Q7.

Crystals of copper(II) nitrate, $\text{Cu}(\text{NO}_3)_2$, can be prepared by reacting solid copper(II) oxide, CuO , with dilute nitric acid.

(a) Write a word equation for this reaction.

(1)

.....

(b) A student is given a sample of copper(II) oxide containing small amounts of insoluble impurities.

The passage is from her notebook and describes the method she uses to prepare some pure, dry crystals of copper(II) nitrate from her sample of copper(II) oxide.

Stage 1: Place 50cm^3 of dilute nitric acid into a beaker and warm.

Stage 2: Add the impure copper(II) oxide a little at a time and stir, until it is in excess.

Stage 3: Filter the mixture.

Stage 4: Heat the filtrate until the crystallisation point is reached.

Stage 5: Allow the filtrate to cool.

Stage 6: Filter off the crystals and dry with filter paper.

(i) Why is the acid warmed in stage 1?

(1)

.....

.....

(ii) How will the student know when the copper(II) oxide is in excess in stage 2?

(1)

.....

.....

(iii) How will the student know when the crystallisation point is reached in stage 4?

(1)

.....

.....

(iv) In which stage are the insoluble impurities removed?

(1)

.....

(Total for question = 5 marks)

Q8.

This question is about the separation of mixtures.

(a) The table shows some methods used to separate mixtures.

(i) Place a tick (✓) in one box in each row of the table to show the best method of separation for each mixture.

(4)

Separation		Method of separation			
		Chromatography	Simple distillation	Filtration	Fractional distillation
P	red ink from a mixture of coloured inks				
Q	ethanol from a mixture of ethanol and water				
R	sand from a mixture of sand and water				
S	water from copper(II) sulfate solution				

(ii) Which of the mixtures P, Q, R or S contains an undissolved solid?

(1)

.....
(b) Pure dry crystals of magnesium nitrate can be obtained from magnesium nitrate solution by crystallisation.

These steps describe the method, but the steps are in the wrong order.

- A allow the solution to cool to room temperature
- B heat the solution to evaporate some of the water
- C pour the mixture of crystals and solution through filter paper
- D put the crystals in a warm place to dry
- E dip a glass rod into the solution to see if crystals form

Write a letter in each box to show the correct order.

One has been done for you.

(2)

	E			
--	---	--	--	--

(Total for question = 7 marks)

Q9.

This question is about tests for some elements and compounds.

(a) What is the test for hydrogen?

(1)

.....
.....

(b) The diagram shows hydrogen burning in air, and how some of the gases passing through the apparatus are collected and tested.

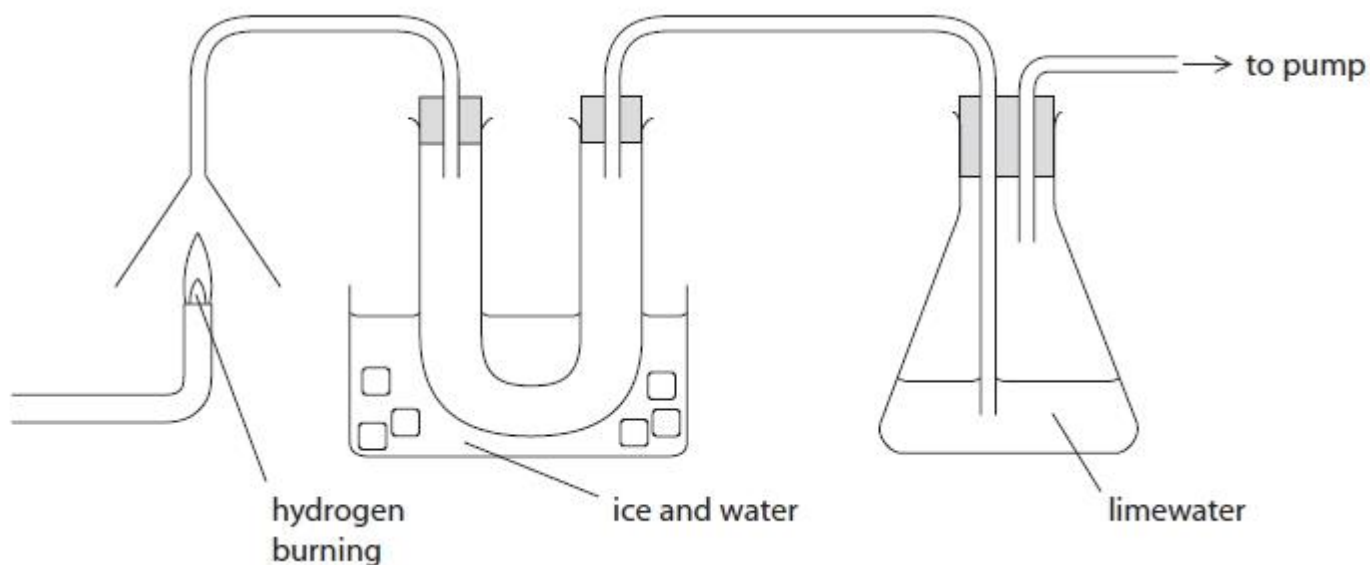

A colourless liquid collects in the U-shaped tube and the limewater turns cloudy **very** slowly.

(i) Describe a **chemical** test to show that the colourless liquid contains water.

(2)

test

.....

result

.....

(ii) Describe a **physical** test to show that the colourless liquid is pure water.

(2)

test

.....

result

.....

(iii) A reaction involving carbon dioxide causes the cloudiness in the limewater.

Place crosses in **two** boxes to show the correct statements about this reaction.

(2)

- carbon dioxide forms when the hydrogen burns
- carbon dioxide from the air reacts to cause the cloudiness
- the cloudiness is caused by the formation of calcium hydroxide
- the cloudiness is caused by the formation of a white precipitate
- the reaction in the limewater is an example of oxidation

(Total for question = 7 marks)

Q10.

A student does an experiment to investigate how the temperature changes as different masses of solid potassium nitrate are dissolved in water.

She looks at this graph to help her decide the masses of water and potassium nitrate to use in her experiment.

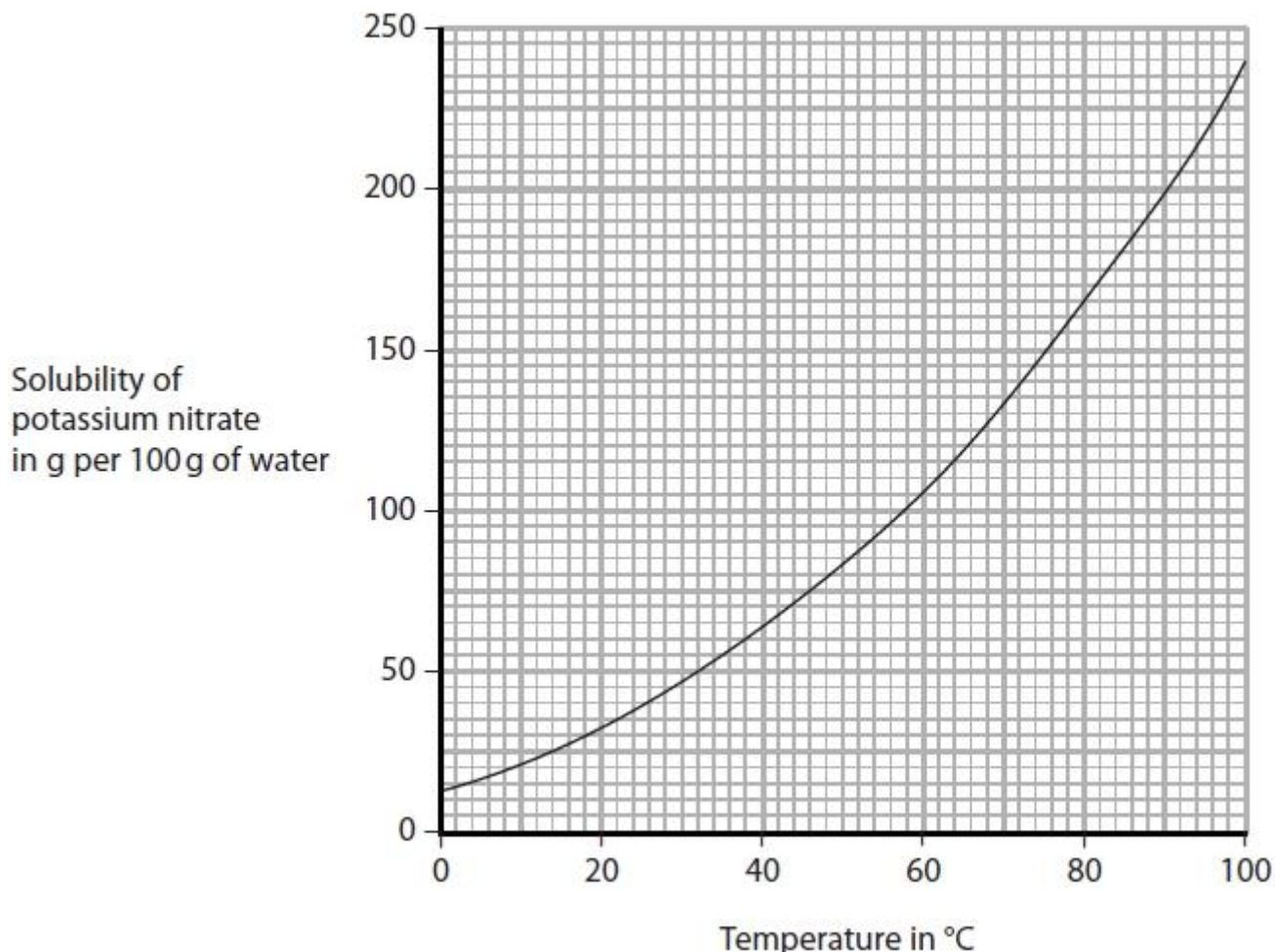

(a) The student decides to use a mass of 50 g of water at a temperature of 25 °C.

From the graph, find the maximum mass of potassium nitrate that dissolves in this experiment.

(1)

(b) The student prepares six samples of potassium nitrate, each with a mass of 2.0 g.

She pours 50 cm³ of water into a 100 cm³ beaker and records the temperature of the water. She then uses this method to find the change in temperature as she adds each sample of potassium nitrate.

- add the first sample of potassium nitrate to the beaker and stir until the sample dissolves
- record the temperature of the solution
- add the second sample of potassium nitrate to the solution in the beaker and stir until the sample dissolves
- record the new temperature of the solution
- repeat until all six samples of potassium nitrate have been added

The table shows her results.

Mass of potassium nitrate added in g	0.0	2.0	4.0	6.0	8.0	10.0	12.0
Temperature in °C	25.2	22.2	19.4	16.9	14.1	11.4	8.8

- (i) Plot the student's results on the grid.
Draw a straight line of best fit.

(3)

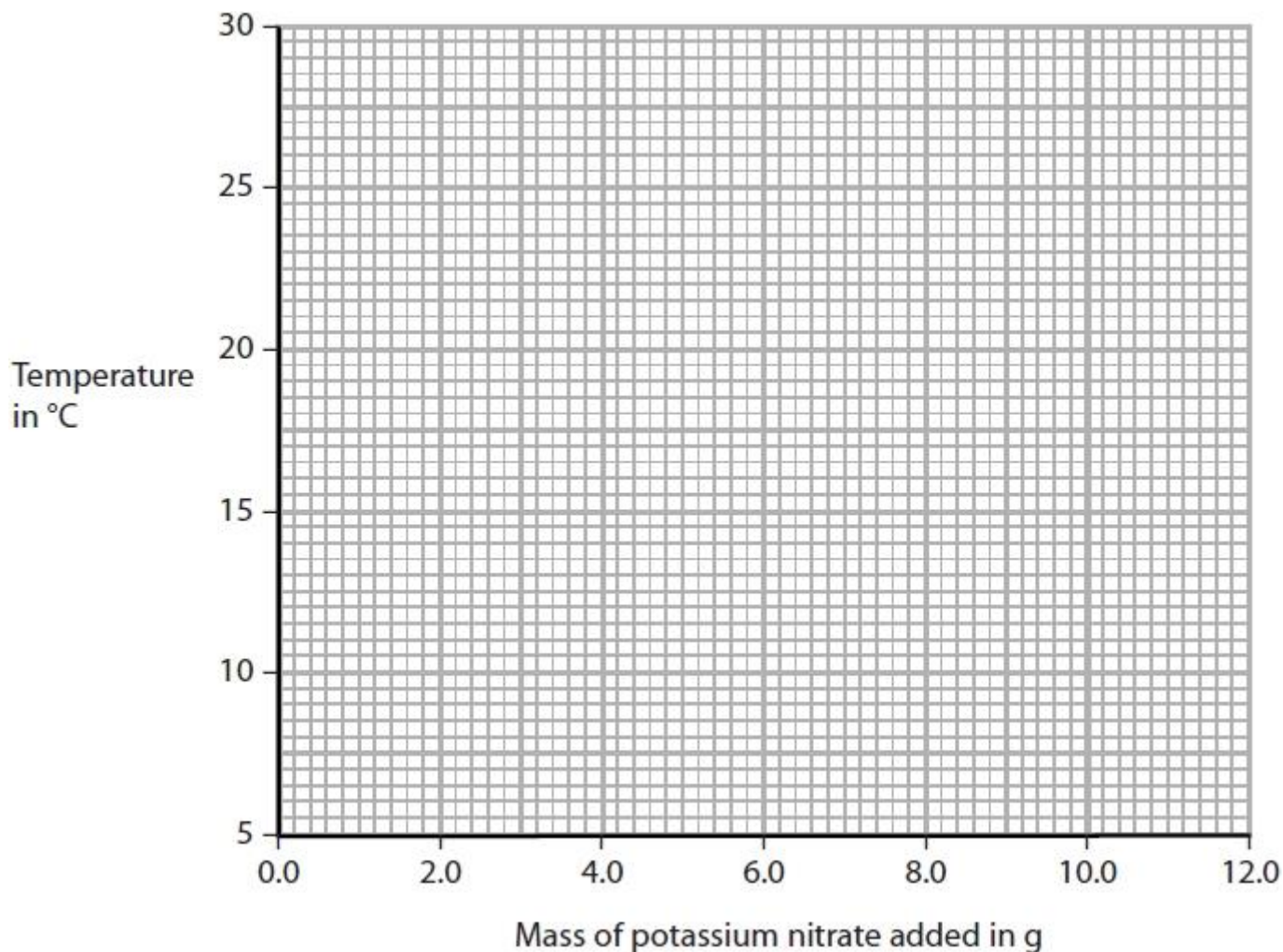

- (ii) From the graph, find the mass of potassium nitrate that would be needed to produce a temperature change of 10.0 °C.

(1)

.....
.....

- (iii) Explain how the student's results show the type of heat change that occurs when potassium nitrate dissolves in water.

(2)

.....
.....

(Total for question = 10 marks)

Q11.

Substances can be elements, compounds or mixtures.

(a) Which of these is a correct symbol for an element?

(1)

- A He
- B H₂
- C H₂O
- D H₂O₂

(b) Which of these substances is a compound?

(1)

- A air
- B hydrogen
- C oxygen
- D water

(c) Which of these methods is used to obtain water from a mixture containing salt and water?

(1)

- A crystallisation
- B filtration
- C simple distillation
- D titration

(d) Paper chromatography is used to separate the dyes present in some inks.

A sample of ink, P, is spotted on to some chromatography paper.

Four known inks, A, B, C and D, are also spotted on to the same paper.

The diagram shows how the experiment is set up and the paper at the end of the experiment.

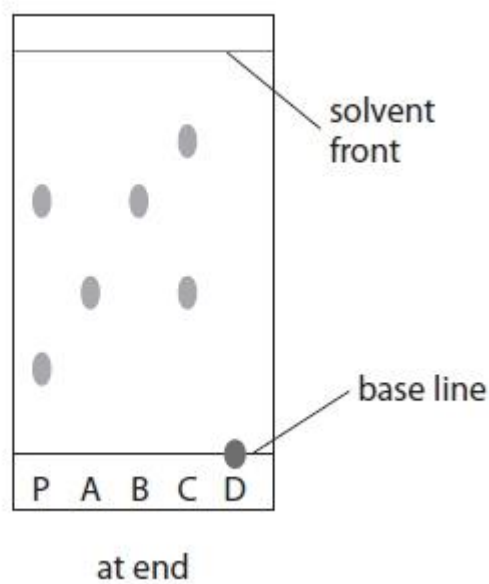
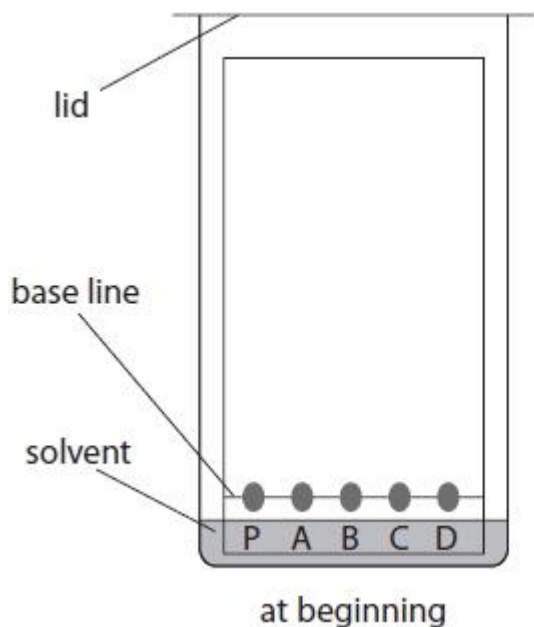

(i) State why the solvent level should not be above the base line at the start of the experiment.

(1)

.....

.....

(ii) Explain which dye, present in one of the inks A, B, C or D, is also present in ink P.

(2)

.....

.....

.....

.....

(iii) State why ink D does not move during the experiment.

(1)

.....

.....

(Total for question = 11 marks)

Q12.



A student was asked to find the mass of salt dissolved in 100 cm³ of sea water. She was given the following instructions.

- Step **A** Weigh an empty evaporating basin
- Step **B** Transfer 50 cm³ of sea water into the basin
- Step **C** Heat the sea water in the basin until all the water has evaporated
- Step **D** Allow the basin and residue to cool
- Step **E** Weigh the basin and residue of salt

(a) During the experiment, the student used several pieces of apparatus. Some of them are shown in the table.

Complete the table.

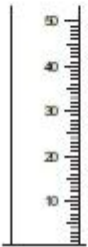
(6)

Image of apparatus	Name of apparatus	One step in which the apparatus was used
	<p style="text-align: center;">evaporating basin</p>	<p style="text-align: center;">C</p>
	<p>.....</p>	<p>.....</p>
<p>.....</p>	<p style="text-align: center;">tripod</p>	<p>.....</p>
	<p>.....</p>	<p>.....</p>

(b) State, with a reason, **one** safety precaution that the student should take when doing this experiment.

(2)

Precaution

Reason

(c) The student obtained the following results.

mass of basin and salt (step **E**) = 81.50 g

mass of empty basin (step **A**) = 78.60 g

Calculate the mass of salt dissolved in **100 cm³** of sea water.

(1)

Mass of salt = g

(Total for Question = 9 marks)

Q13.

Rusting occurs when iron is exposed to air and water. During rusting, iron reacts with oxygen from the air to form an oxide.

Some students set up this apparatus to measure the volume of oxygen in a sample of air.

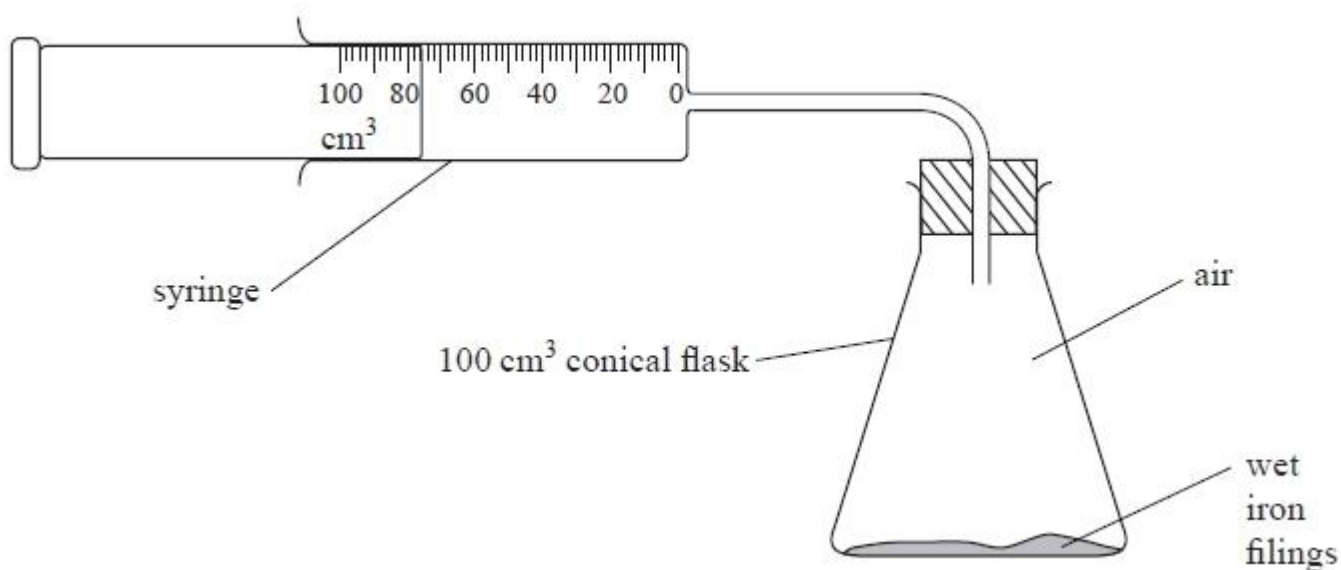

Each student used an excess of wet iron filings.

At the start of the experiment the reading on the syringe was recorded and the apparatus was then left for a week until the reaction was completed.

At the end of the experiment the reading on the syringe was recorded again.

(a) The syringes used in one student's experiment are shown below.

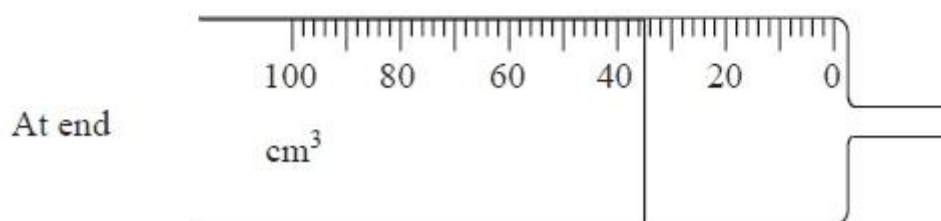
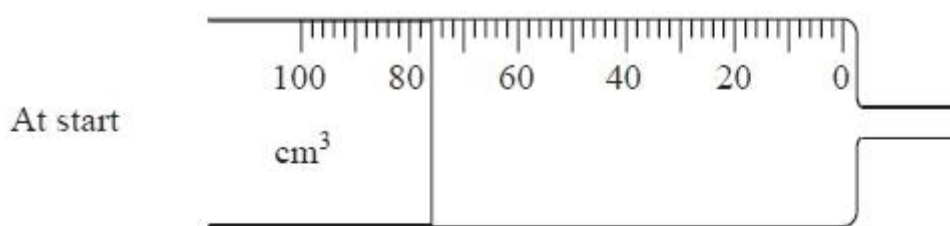

Record the syringe readings at the start and at the end of the experiment in the table below, and calculate the volume of oxygen used up.

Syringe reading at start in cm^3	
Syringe reading at end in cm^3	
Volume of oxygen used up in cm^3	

(3)

(b) The results of the other students are shown in the table.

Total volume of air at start in cm^3	Total volume of gas at end in cm^3	Volume of oxygen used up in cm^3
200	160	40
180	144	36
165	140	25
150	120	30
185	148	37

(i) Use the results in the table to plot a graph of volume of oxygen used up against volume of air at start. Draw a straight line of best fit.

(3)

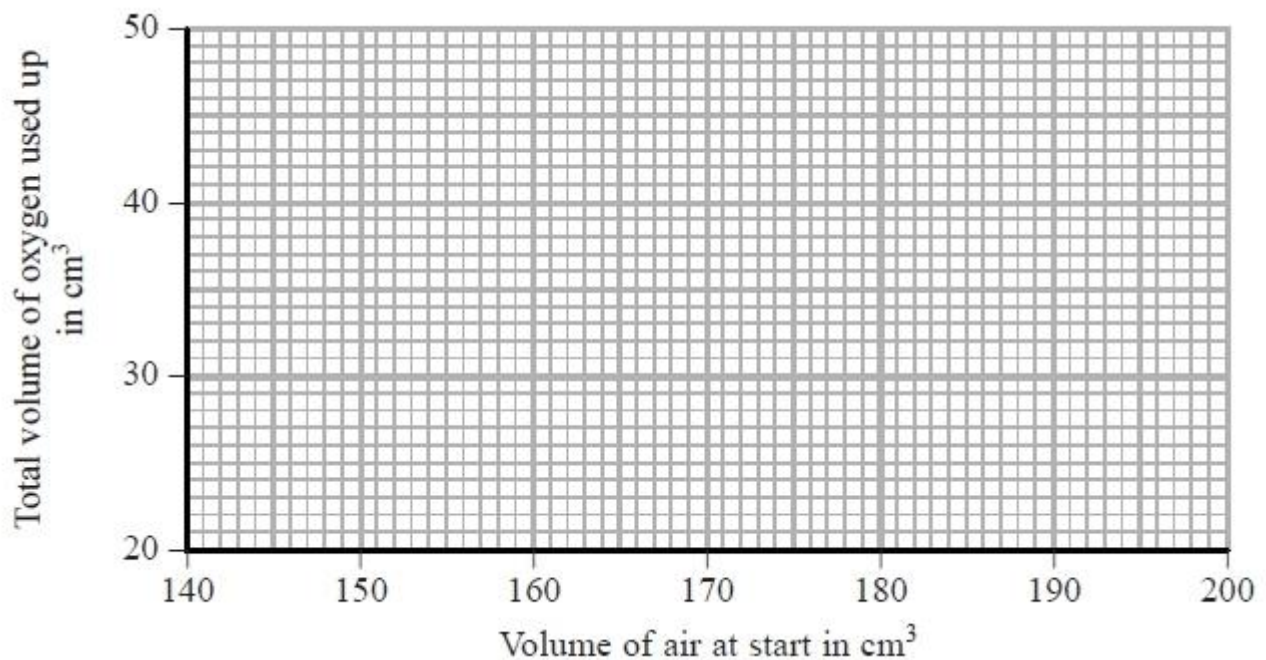

(ii) One of the results is anomalous. Identify this result by circling it on the graph.

(1)

(c) Another group of students did experiments that gave several anomalous results. The teacher discussed possible errors that could have caused these anomalous results.

Complete the table by choosing words from the following list to show what effect each error would have on the volume of oxygen used up.

decreased

increased

no change

Possible error causing anomalous result	Effect on volume of oxygen used up
iron filings not in excess	
experiment left for 1 day instead of 1 week	
apparatus left in warmer place for 1 week	

(3)

(d) Use the following results to calculate the percentage of oxygen in air. Give your answer to one decimal place.

Total volume of air at start in cm ³	140
Volume of gas at end in cm ³	111

(2)

..... %

(Total for question = 12 marks)

Q14.

The melting points of three related compounds are

capric acid 32 °C

formic acid 8 °C

palmitic acid 63 °C

The boiling point of all these compounds is above 100 °C

(a) Use the grid to draw a bar chart of the melting points.

(2)

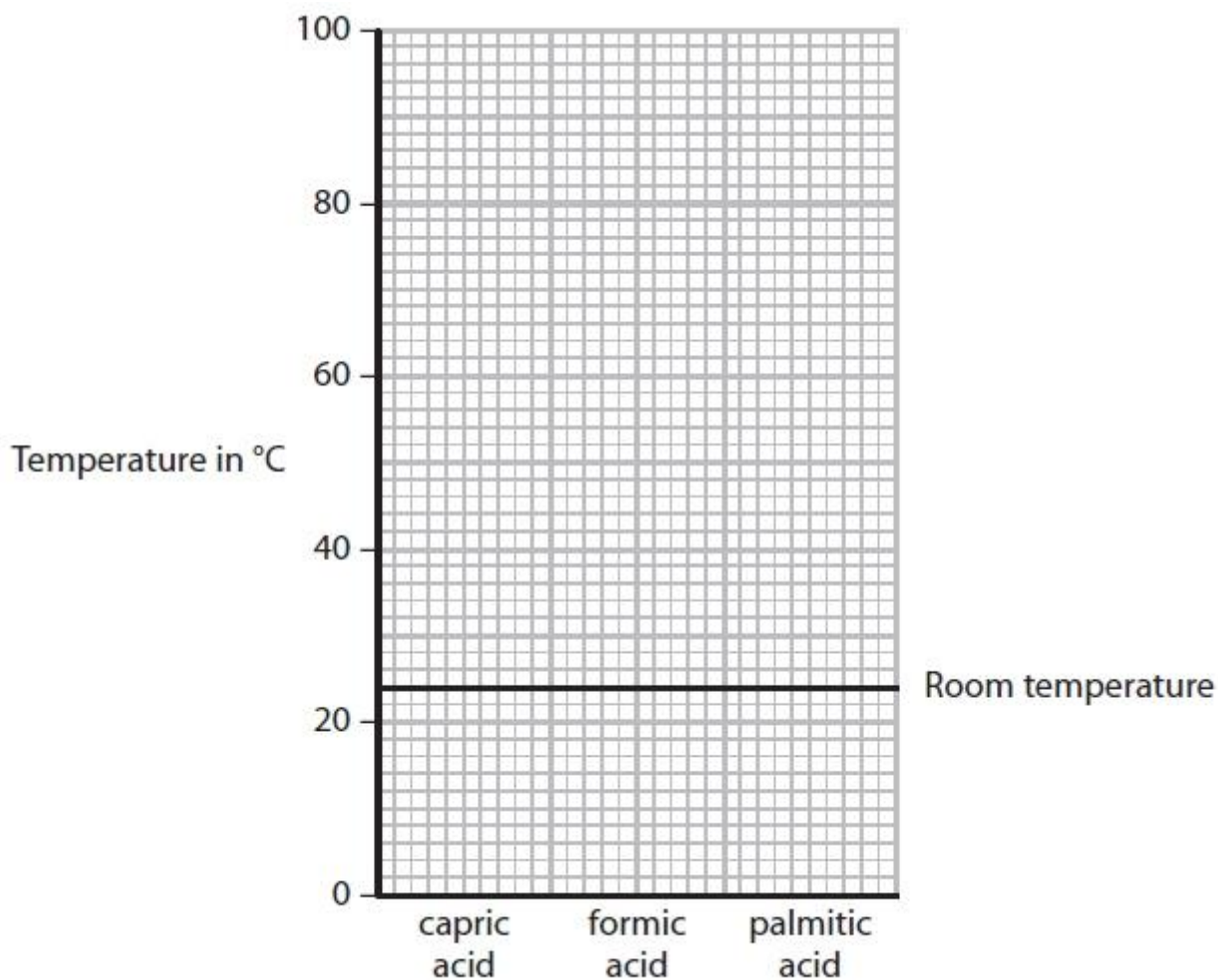

(b) Room temperature has been marked on the grid.

Use your bar chart to give the physical state of each acid at room temperature.

(2)

capric acid

.....

formic acid

.....

palmitic acid

.....

(Total for Question = 4 marks)

(b) How would the student know when she has added an excess of zinc carbonate?

(1)

.....
.....

(c) Name the separation method used in step 3.

(1)

.....

(d) The student wants to obtain a pure, dry sample of hydrated zinc nitrate crystals from the dilute solution.

One method is to leave the solution so that all the water evaporates.

Describe another method, involving crystallisation, that the student could use.

(4)

.....
.....
.....
.....
.....
.....
.....
.....
.....
.....

(Total for question = 7 marks)

Q17.

A student carries out an investigation to compare the reactivities of four metals, aluminium, copper, zinc and M.

He adds strips of zinc to the aqueous solutions of the nitrates of each metal.

After a few minutes he removes the strips of zinc and examines them.

The table shows his results.

Solution	Result
aluminium nitrate	no change
copper(II) nitrate	brown coating on zinc
zinc nitrate	no change
nitrate of metal M	grey coating on zinc

(a) Name the substance that causes the brown coating on the zinc.

(1)

.....

(b) State why there is no change in the experiment with zinc nitrate solution.

(1)

.....

.....

(c) The student repeats the experiment with strips of metal M instead of strips of zinc. The table shows his results.

Solution	Result
aluminium nitrate	no change
copper(II) nitrate	brown coating on M
zinc nitrate	no change
nitrate of metal M	no change

Using information from both tables of results, place the metals aluminium, copper, zinc and M in order of decreasing reactivity.

(2)

most reactive

.....

.....

least reactive

(Total for question = 4 marks)

Q18.

Iron is a metal with many uses. One problem with using iron is that it rusts.

(a) Name two substances needed for iron to rust.

(2)

..... and

(b) State the name of the main compound present in rust.

(1)

.....

(c) The table shows three methods used to protect iron from rusting.

Choose three of the objects from the box to complete the table.

You may choose an object only once.

(3)

bicycle chain	bucket	car body
car engine	food can	railway bridge

Method	Example of use
galvanising	
oiling	
painting	

(d) An iron object is coated with zinc to protect it from rusting. This protection continues even if the zinc coating becomes scratched.

Explain how the zinc coating protects iron from rusting.

(2)

.....
.....
.....
.....
.....
.....

(Total for question = 8 marks)

Q19.

This apparatus is used to separate a mixture of ethanol (boiling point 78 °C) and water (boiling point 100 °C).

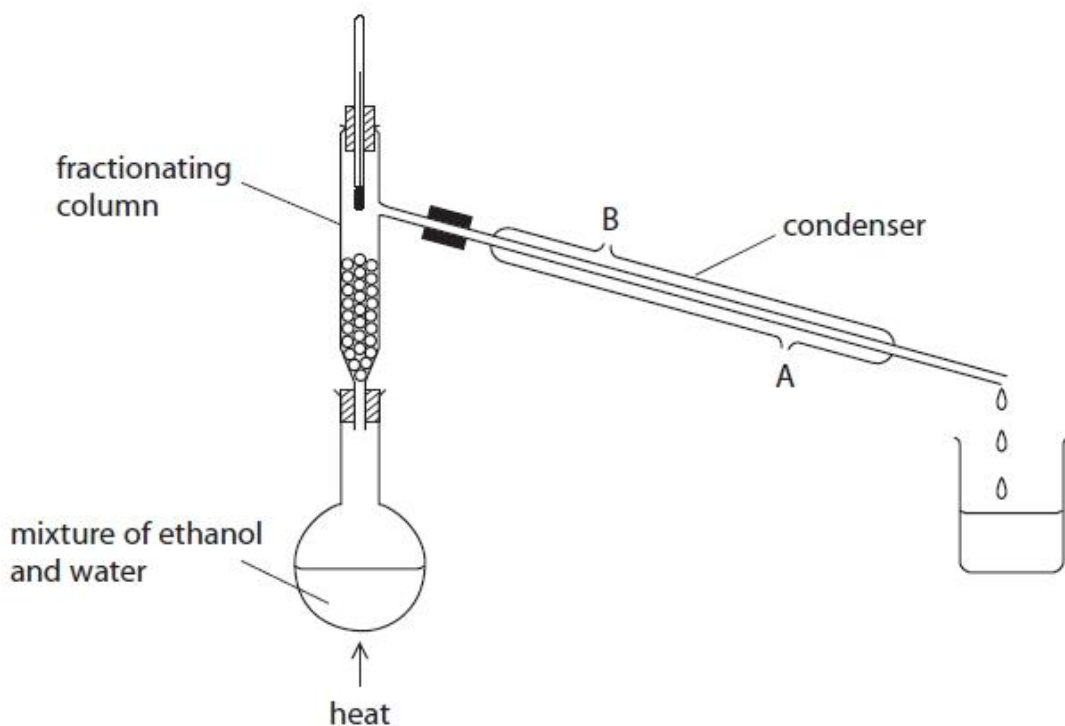

(a) What is the name of this method of separation?

(1)

.....

(b) Why can ethanol and water be separated by this method?

(1)

.....

.....

(c) Suggest why water should enter the condenser at A rather than B.

(1)

.....

.....

(d) Explain why the first liquid to be collected in the beaker is mostly ethanol.

(1)

.....

.....

(Total for question = 4 marks)

Q20.

(a) Substances can be classified as elements, compounds or mixtures.

Each of the diagrams below represents either an element, a compound or a mixture.

State which one of these is represented by each diagram.

(i)

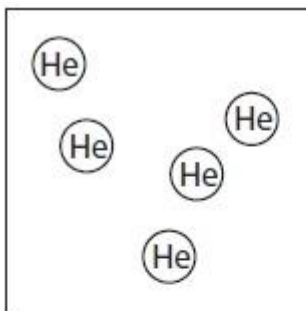

.....
(1)

(ii)

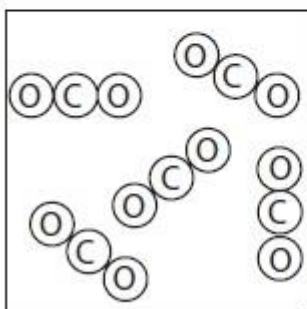

.....
(1)

(iii)

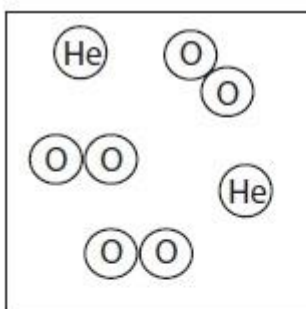

.....
(1)

(iv)

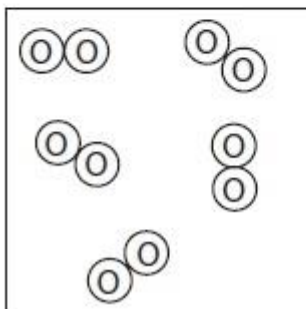

.....
(1)

(b) Substances can also be classified as solids, liquids or gases.
Each of the diagrams below represents either a solid, a liquid or a gas.
State which one of these is represented by each diagram.

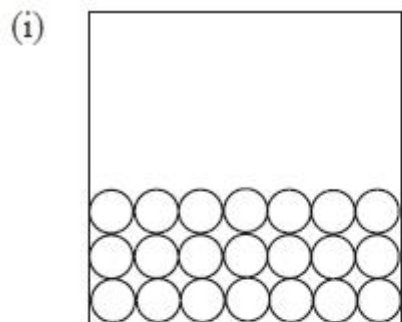

.....
(1)

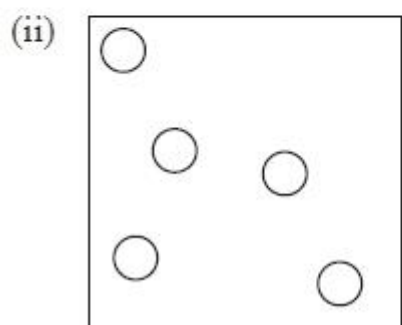

.....
(1)

(Total for question = 6 marks)

Q21.

This question is about the states of matter.

(a) The diagram shows the three states of matter for a substance.

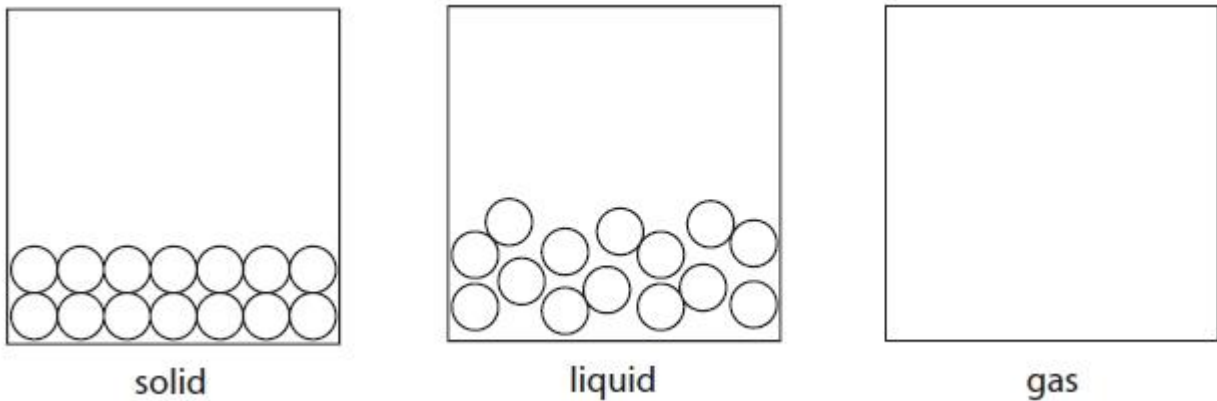

Each circle represents a molecule of the substance.

(i) Complete the diagram by drawing six circles to represent molecules in the gas state.

(1)

(ii) Which statement is correct about the movement or arrangement of the molecules of this substance?

(1)

- A** They move randomly in the solid state.
- B** They move randomly in the liquid state.
- C** They are arranged in fixed positions in the liquid state.
- D** They are arranged in fixed positions in the gas state.

(iii) Which term is used for a solid changing to a liquid?

(1)

- A** boiling
- B** condensing
- C** freezing
- D** melting

- (b) Some cold water is poured into a conical flask and a bung inserted.
The diagram shows the flask after a few minutes.

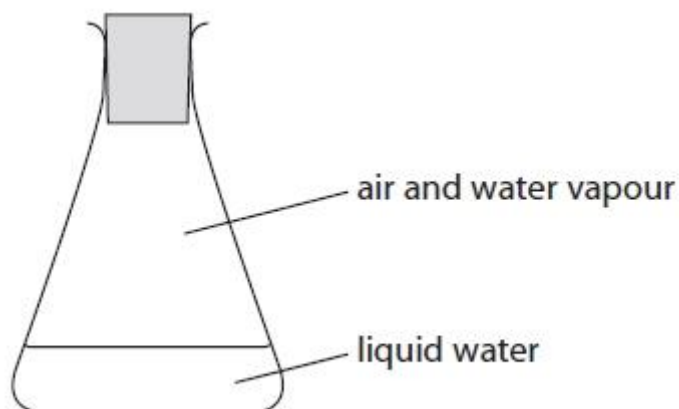

- (i) What is occurring in the flask?

(1)

- A boiling and condensing
- B condensing and evaporating
- C evaporating and freezing
- D freezing and melting

- (ii) Which formula represents a substance that is **not** present in the flask?

(1)

- A $\text{H}_2\text{O}(\text{g})$
- B $\text{H}_2\text{O}(\text{l})$
- C $\text{N}_2(\text{g})$
- D $\text{N}_2(\text{l})$

(Total for question = 5 marks)

Q22.

This question is about different metals.

The list shows part of the reactivity series of metals.

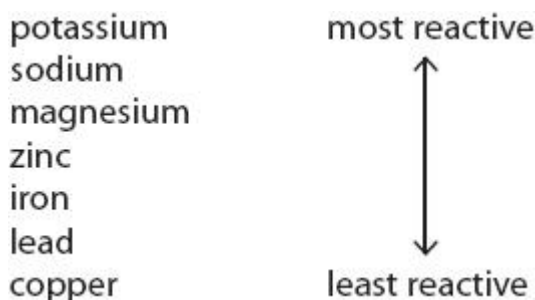

(a) Name a metal from the list that is extracted by electrolysis.

(1)

.....

(b) Uranium is a metal that is in between magnesium and zinc in the reactivity series.

Equal sized pieces of these three metals are placed in separate solutions of dilute hydrochloric acid of the same concentration and at the same temperature.

The observations for magnesium and zinc are shown in the table.

Complete the table by stating the observations that would be made for uranium.

(2)

Metal	Observations
magnesium	Bubbles of gas produced very rapidly. Solid disappears very quickly.
zinc	Bubbles of gas produced slowly. Solid disappears slowly.
uranium	

(c) (i) Metals high in the reactivity series react readily with water.

Name the compound formed when potassium reacts with water.

(1)

.....

(d) Zinc can be extracted by heating zinc oxide with carbon.

The equation for the reaction is

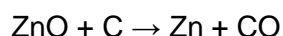

(i) Explain whether zinc or carbon is the more reactive element.

(1)

.....

.....

(Total for question = 5 marks)